

LOC		DIST		P		F		ZONE		LTR		REVISIONS		DATE	APPD
CM	53											H	REV PER EC 0730-0210-95	2-8-96	RV

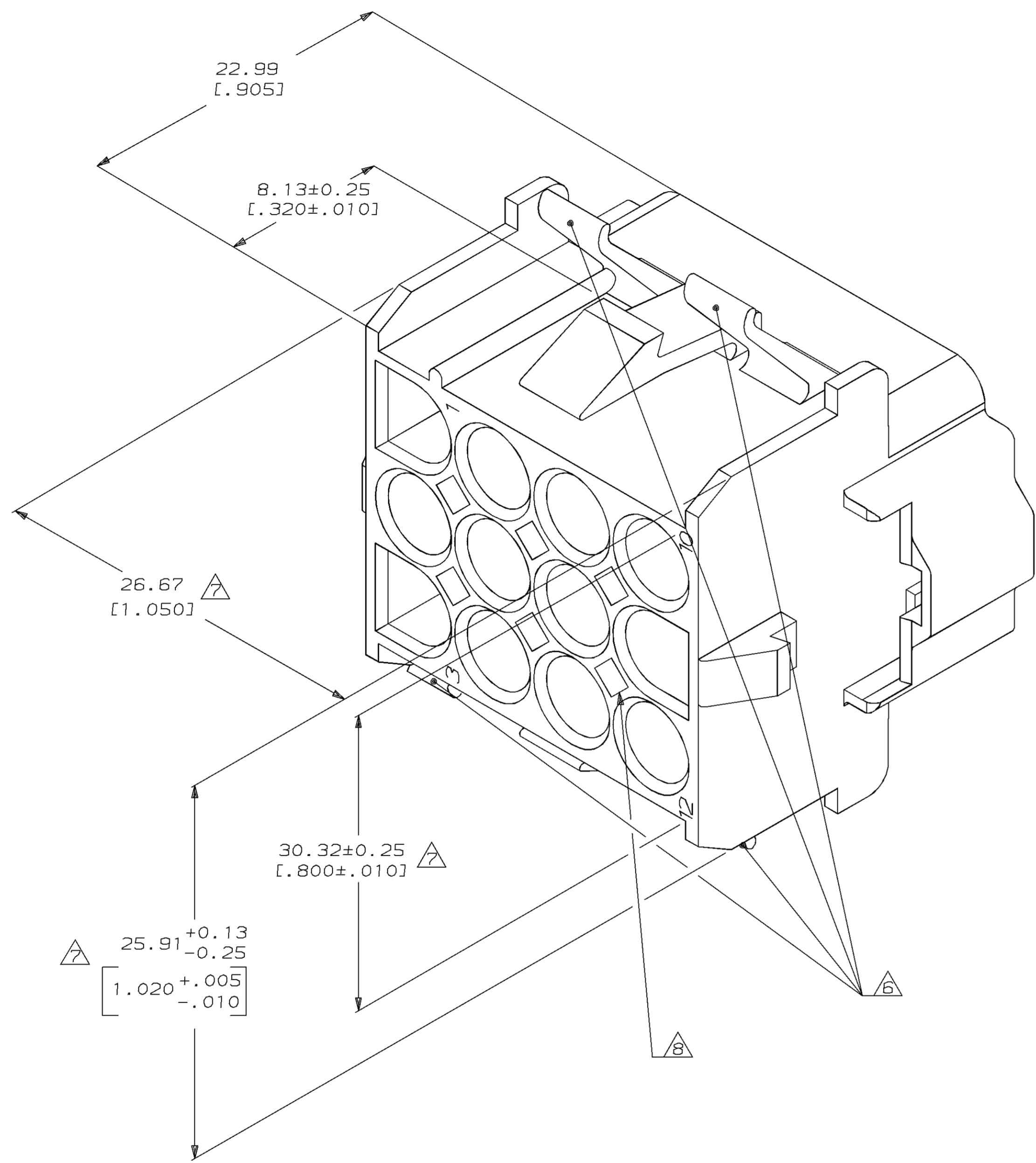

- MUST BE ASSEMBLED WITH CAP REAR P/N 770056-1 BEFORE MATING. KIT P/N IS 770029-1.
- RECOMMENDED PANEL THICKNESS 0.76-2.29 [.030-.090].
- PANEL MUST BE PUNCHED SO THAT THE HOUSING ENTERS THE PANEL IN THE SAME DIRECTION AS THE PUNCH.
- OPTIONAL FOR KEYING HOUSING IN PANEL.
- CIRCUIT NUMBER 1 LOCATION.
- AMP LOGO LOCATED ONCE ON ANY INDICATED SURFACE FAR SIDE.
- DIMENSION INDICATED IS AS MOLDED. ADDITIONAL GROWTH DUE TO SUBSEQUENT MOISTURE ABSORPTION MAY OCCUR.
- OPTIONAL CONSTRUCTION PROVIDES ROUND MATERIAL REDUCTION CORING HOLES.

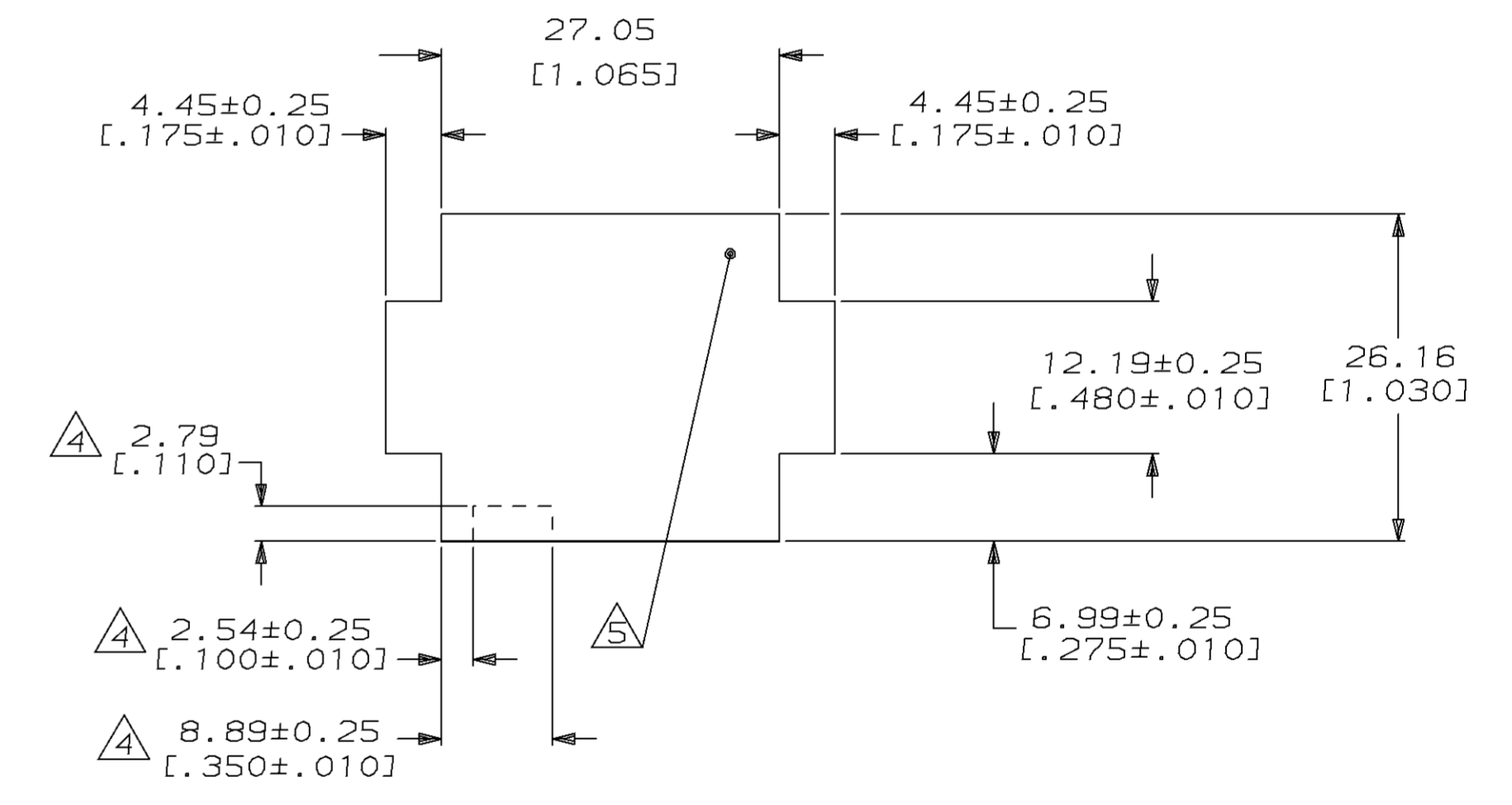

RECOMMENDED PANEL CUTOUT  
 (HOUSING ENTRY SIDE)  
 SCALE 2:1

2 3

770055-1  
 PART NUMBER



DO NOT SCALE PRINT. UNLESS SPECIFIED DIMENSIONS IN INCHES TOLERANCES ON:		DR 1-15-92 K. SALMON		PART NO	
1 ± .005		CHK 1-15-92 R. SWING		AMP INCORPORATED Harrisburg, Pa. 17105	
2 ± .005		APPD 1-16-92 M. TRULL		NAME	
3 ± .005		APPD 1-16-92 M. TRULL		CAP FRONT, 12 CIRCUIT, UNIVERSAL MATE-N-LOK™ II	
MATERIAL NYLON, UL94V-0,		PRODUCT SPEC		SIZE D	
FINISH		APPLICATION SPEC		FSCM NO 00779	
WEIGHT		SCALE 5:1		DRAWING NO 770055	
				SHEET 1 OF 1	

CUSTOMER DRAWING